

Casting Future Perfection

QINGDAO EVERGREEN MACHINERY CO., LTD.

QINGDAO Evergreen Machinery Co., Ltd.



Founded in 2013 in the port city of Qingdao, China, privately owned
Started as a small workshop, gradually built multi-process manufacturing and engineering competence



In 2025, we have a team of around 300 people and our revenue exceed USD 28 Mil.



Headquarter:
administration, marketing, R&D, application engineering, prototyping, quality control
Plant:
casting, machining, metal works, stamping and welding

About Us

Milestones

- Worldwide market focused
- ISO9001 re-certificate
- ISO14001 certificate
- ISO45001 certificate
- New Pilot Run base set up
- Facility moved to new site

- In-house machining, welding and stamping.
- EN15085 certificate
- ISO3834 certificate
- IATF16949 certificate

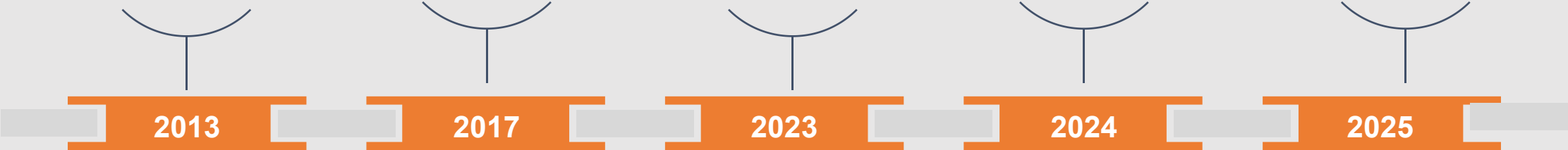

A Team of Dedicated Engineers:

- » All hold university degrees in mechanical engineering
- » Rich experience in working for and with international companies
- » Combined expertise of decades in the industry
- » Capable to get involved in your product development at a very early stage
- » Competent consultant for design, optimizing or production feasibility
- » In house tool design and Mould flow analysis
- » 3D Scan/3D Printing



Engineering Center

Developing R&D capability

◆ 3D Scan



◆ Mould Flow analysis

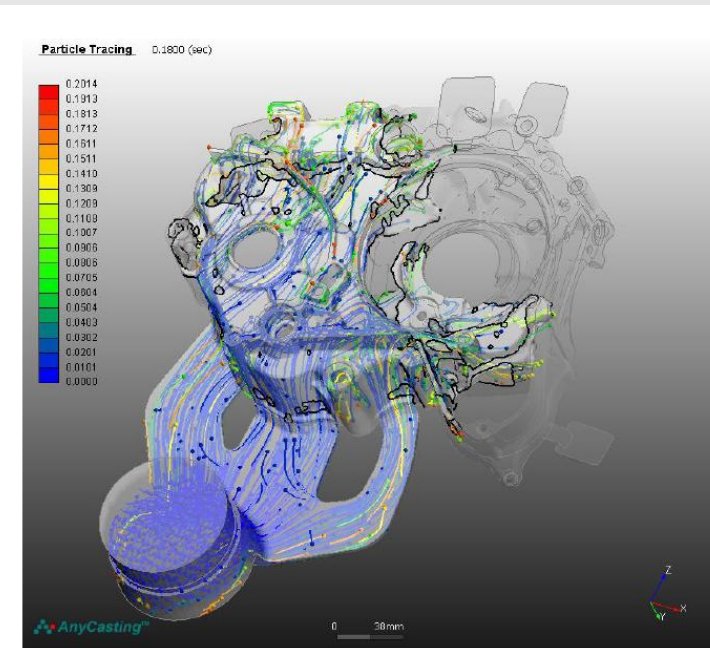
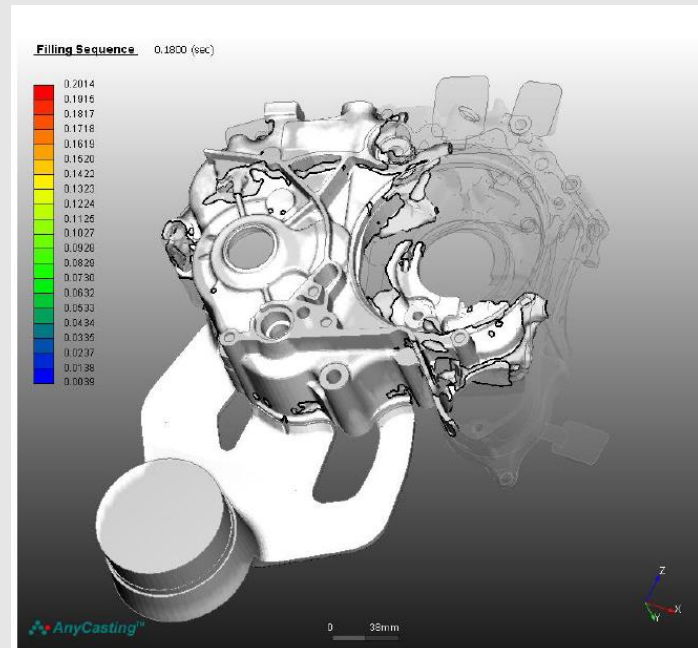

ISO 9001/ISO14001/ISO45001 / EN 15085/ISO3834/IATF16949 certified



Certified Quality

Coordinate Measurement, Spectrum, Hardness, Optical, Mechanical and Microstructure Testing, Salt Spray test, Impact test, NDT



Assured Quality



From material intake to delivery of the finished product - we provide full quality inspection and documentation

标准检验指导书 (SIP)
STANDARD INSPECTION PROCEDURE

品名 Part Name	Mount	图号/版本 Drawing No./Rev	H86013059
材料 Material	Q355D +CR	表面处理 Surface Treatment	环保镀锌 Fe/Zn12/Cr/TO
生产状态 Production Status	Sample 样件	检验检验方式 Inspection Method	按图检验 Source Inspection

图示说明 Photo illustration

序号 No.	规格/公差 Spec/Tolerance	判定符号 Symbol	检验方法 Inspection Method	检验水平 Inspection Level
1	外观/公差 表面光滑, 无划伤毛刺, 缺陷, 锈蚀, 油污, 金属部位无锈蚀和漆层脱落, 漆层表面无脱落和锈迹	*	目视/手试	IL=1
2	装配/配合 金属表面镀锌, 镀锌厚度12um, 无漏镀, 锈点, 麻点, 气泡, 脱落等缺陷	*	目视/显微镜	IL=1
3	Marking 标识 在指定区域标识 CHEGET 商标, 零件号及其类型, 生产日期, 标识正确清晰	*	目视	IL=1
4	Material 材质 屈服强度 中心村不低于355Mpa, 外壳不低于235Mpa	*	实验室报告	每批 Each Lot
5	Material 材质 除了橡胶 工作温度范围 -40~90度	*	实验室检查报告	每批
6	Material 材质 转向角度 1500±20%	*	角度测试机	每批

尺寸检查 Dimensional Check

SIP

质量检验报告 (检验记录)
INSPECTION REPORT

品名 Part Name	Mount	图号/版本 Drawing No./Rev	H86013059
材料 Material	Q355D +CR	表面处理 Surface Treatment	环保镀锌 Fe/Zn12/Cr/TO
生产状态 Production Status	Sample 样件	批次数量 Lot Qty	

图示说明 Photo illustration

序号	检查项目	判定符号	检查方法	标准要求	检查结果	判定/备注
1	Appearance 外观	*	目视/手试	表面光滑, 无划伤毛刺, 缺陷, 锈蚀, 油污, 金属部位无锈蚀和漆层脱落, 漆层表面无脱落和锈迹		
2	Assembling 装配/配合	*	目视/显微镜	金属表面镀锌, 镀锌厚度12um, 无漏镀, 锈点, 麻点, 气泡, 脱落等缺陷		
3	Marking 标识	*	目视	在指定区域标识 CHEGET 商标, 零件号及其类型, 生产日期, 标识正确清晰		
4	Material 材质	*	实验室报告	屈服强度 中心村不低于355Mpa, 外壳不低于235Mpa		
5	Material 材质	*	实验室检查报告	除了橡胶 工作温度范围 -40~90度		
6	Material 材质	*	角度测试机	转向角度 1500±20%		

尺寸检查 Dimensional Check

QC Report



Transparent Quality

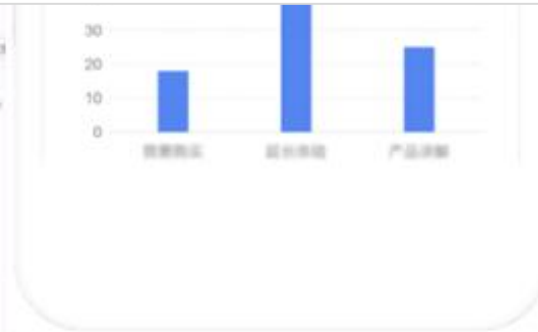

Why EVERGREEN?

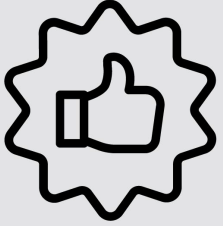

Quality

Reliably documented and transparent in process

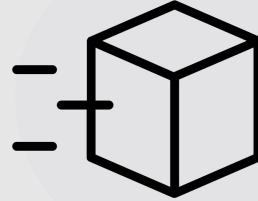

Delivery

On time and in the right packaging



Cost

Competitive and always fair



Service

Comprehensive and customer oriented



BRUNSWICK



ZOLLERN

PANDROL



Our Strategic Partners

EVERGREEN MACHINERY products are used in the following industries:

- ∞ Medical Equipment
- ∞ Telecommunication
- ∞ Logistics
- ∞ Construction and agricultural machinery
- ∞ Heavy trucks
- ∞ High speed trains

... and many others...



Applications

Global markets



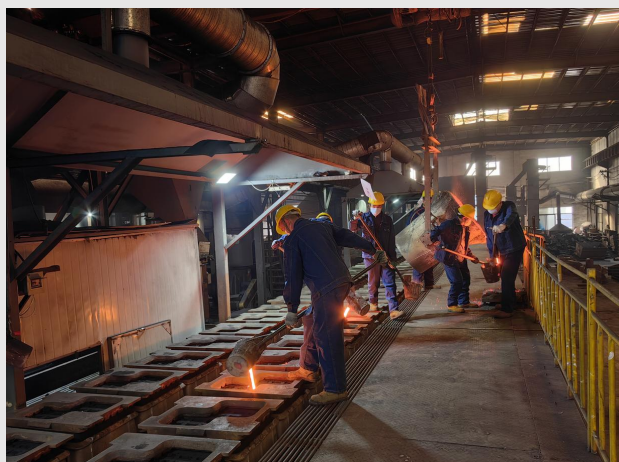

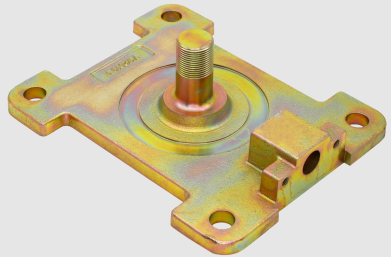
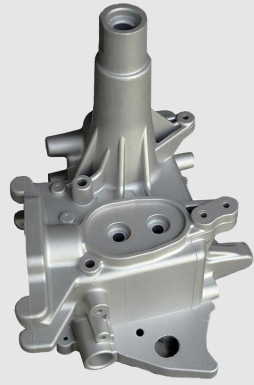
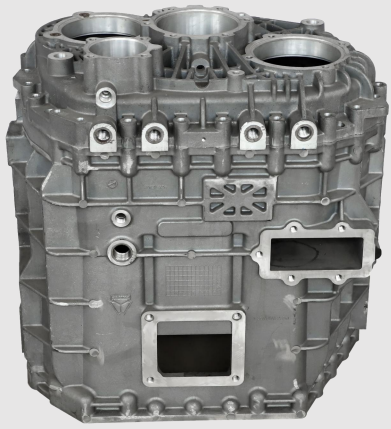

CASTING

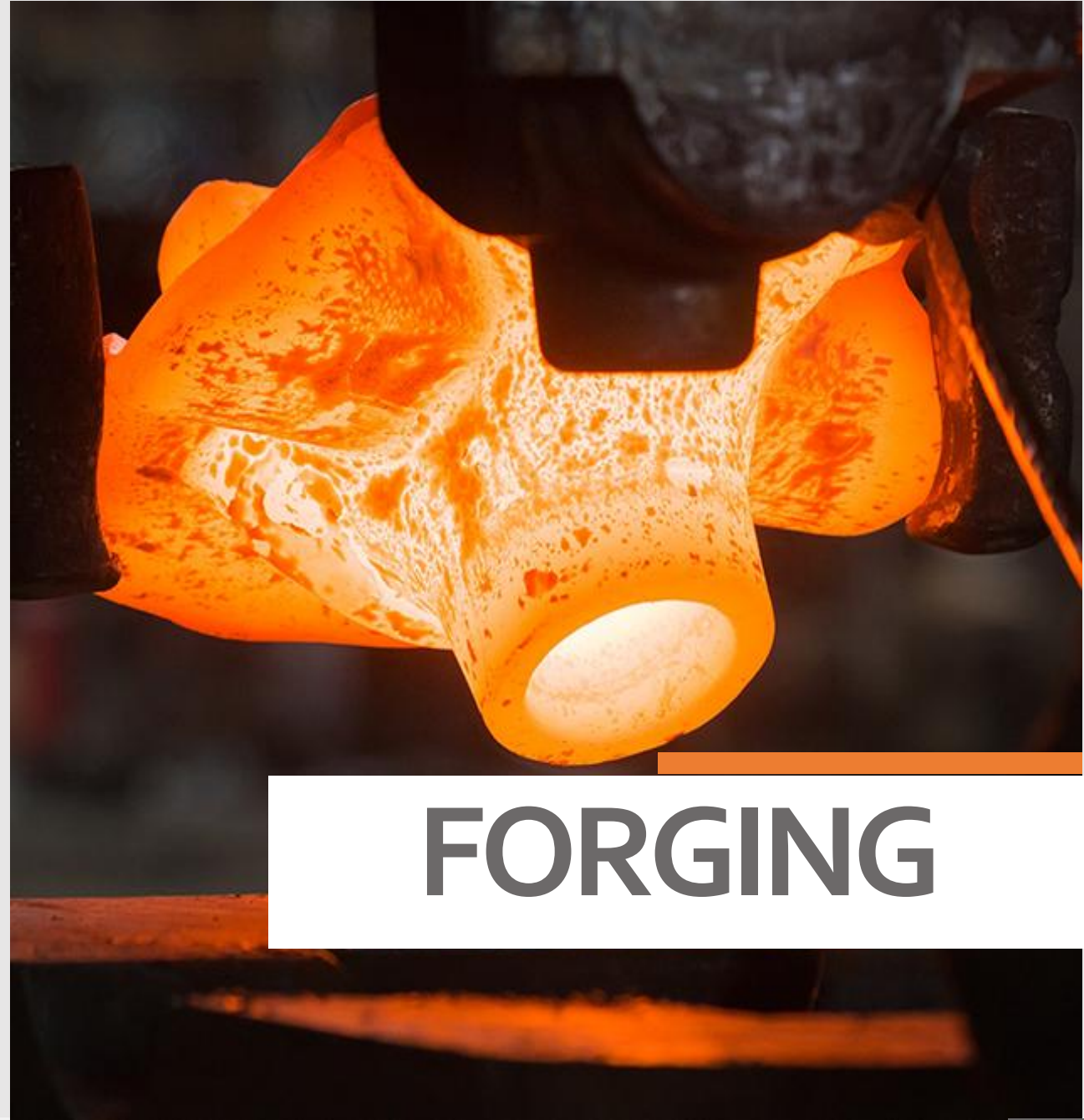

FORGING

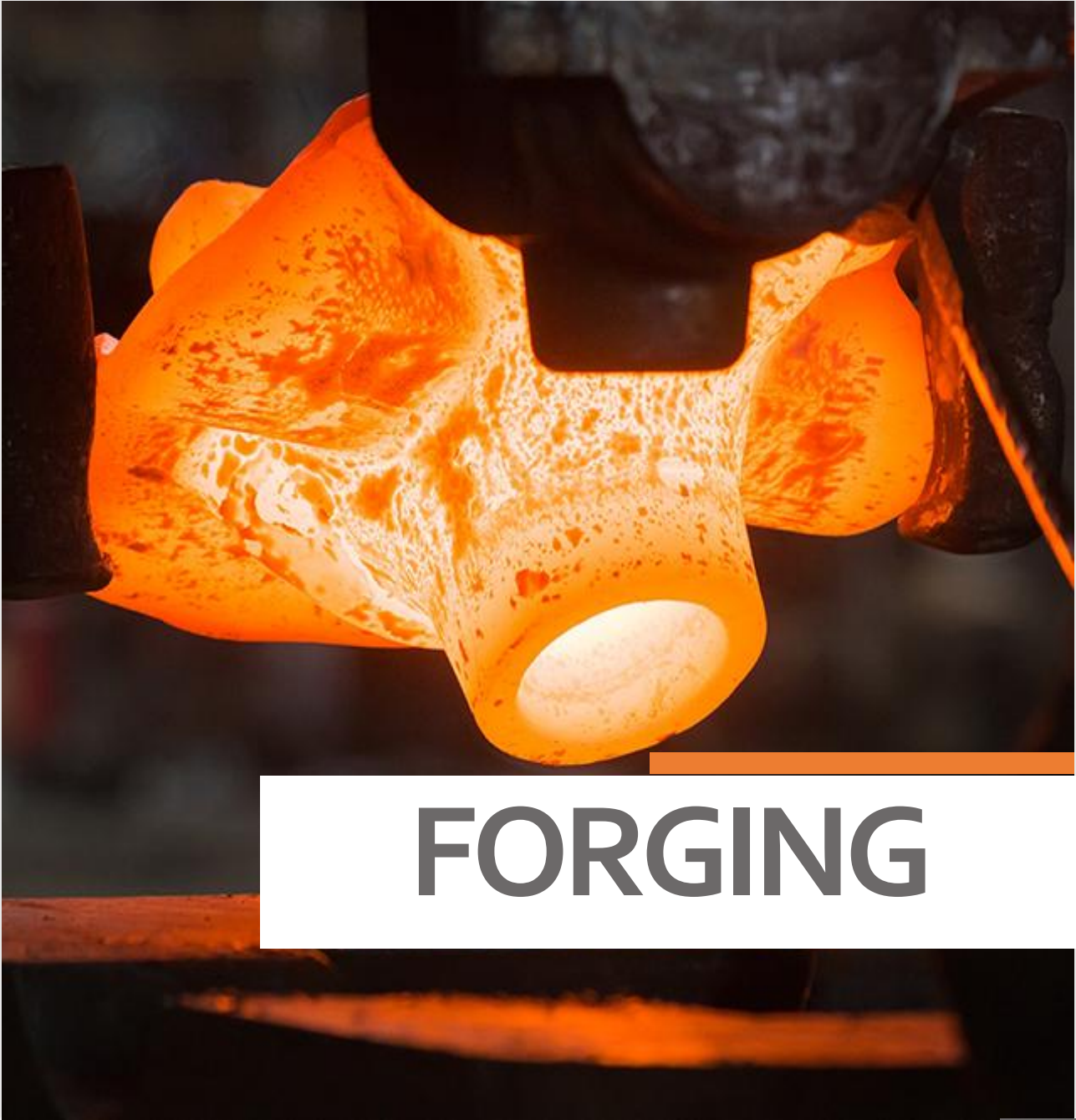
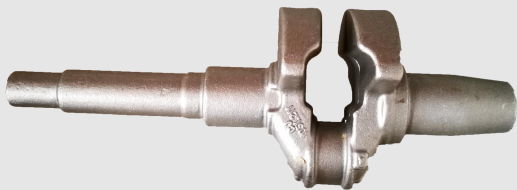

FORGING



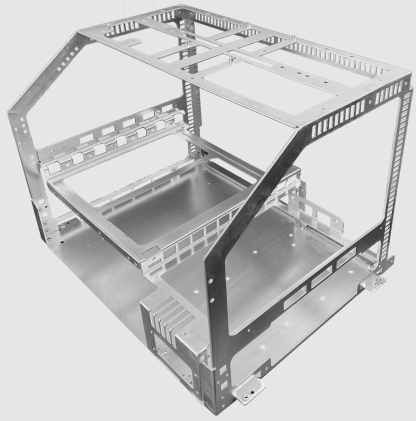

METAL WORKS



Headquarter in Qingdao,
Pilot Run base as well.



Manufacture Base in Gaomi,
Casting, Machining, Metal Work & Fabrication.



诚信
INTEGRITY

感恩
GRATITUDE

TEAM



EVERGREEN

维青机械欢迎您

Welcome Visit EVERGREEN Machinery



Qingdao Evergreen Machinery Co., Ltd.
Headquarter:
No. 1 Loushan Road, Licang District
Qingdao 266043

Plant:
Liquan Industrial Park, Gaomi Town,
Shandong Province, P. R. China

Tel.: +86 532 6898 3026
Fax: +86 532 6619 5037
Email: info@qd-evergreen.com
Website: www.qd-evergreen.com